

ULTRA-LOW NO_x ATMOSPHERIC

Residential Gas Water Heaters

American Standard[®]

WATER HEATERS

www.americanstandardwaterheaters.com

Features

- **ULTRA-LOW NO_x BURNER** – Complies with Southern California SCAQMD 2008 Rule 1121 and Northern California BAAQMD 2009 10ng/J NO_x emissions requirements.
- **VAPORSHIELD TECHNOLOGY** – Unique design that prevents flames from traveling backwards through the flame arrestor plate and outside of the water heater if flammable vapors are present, providing extra protection.
- **TRADITIONAL MECHANICAL GAS VALVE** – Simple and maintenance free operation.
- **SPARK IGNITER** – Easy push button pilot lighting in lieu of matches.
- **FACTORY INSTALLED ENERGY CUT-OFF SYSTEM** – Automatic thermostat with built-in gas pressure regulation also incorporates energy cut-off switch to prevent abnormally high water temperature for added safety.
- **TURBULENCE – INDUCING DIP TUBE** engineered to reduce sediment build-up inside the tank.
- **FULL FLOW BRASS DRAIN VALVE** factory provided & installed, allows easy and quick drainage.
- **FACTORY INSTALLED HEAT TRAPS** reduce standby heat loss caused by heat mitigation to water pipes.
- **TEMPERATURE AND PRESSURE RELIEF VALVE** factory provided & can be relocated from side to optional top of the heater.

Performance

- **Up TO 0.66 UEF**
- **UP TO 86 GALLONS FIRST HOUR RATING (FHR)**
- **HFO FOAM INSULATED** – Up to 2 inch-thick, environmentally-friendly insulation foam saves energy, reduces fuel cost by maximizing heat retention, and contributes to overall energy efficiency.
- **SELECT MODELS CERTIFIED TO 10,100 FEET**
- **CSA DESIGN CERTIFIED** – All models design tested and certified in accordance with CSA / ANSI Z21.10.1 * CSA 4.1.
- **AHRI ENERGY CERTIFIED** – Energy Efficiency tested in accordance with D.O.E. test procedures, meets or exceeds the requirements of ANSI, ASHRAE, and National Appliance Energy Conservation Act.

Quality

- **HEAVY GAUGE STEEL TANK** for extra years of trouble-free service.
- **GLASS-LINED TANK** with DuraGlas™ and fired at 1600°F for optimum protection from the effects of corrosion.
- **MAGNESIUM ANODE ROD** to prolong tank life.
- **CHOICE OF 6- OR 12-YEAR LIMITED TANK WARRANTY** – Standard 6-year warranty for tank and component parts. Upgraded 12-year limited tank warranty includes 12 years on the tank and 6 years on component parts. 12-year upgrade models will include a second anode rod for increased protection.

30, 40 & 50 Gallon Capacities
Tall & Low Boy Configurations
Up to 40k BTU Input
Natural Gas



Globally Recognized. Industry Respected.

225 Dyer St., Providence, RI 02903
Toll Free: (800) 323-9651

GN 05.27.26

SPECIFICATIONS AND APPLICATION DATA

www.americanstandardwaterheaters.com

DIMENSIONS IN INCHES

MODEL NUMBER	NOMINAL CAPACITY (GAL.)	DOE RATED CAPACITY (GAL.)	FIRST HOUR RATING (GAL.)	BTU INPUT NAT GAS	GPH/LPH RECOVERY @ 90° RISE	UNIFORM ENERGY FACTOR (UEF)	VENT DIAM (IN) A	JACKET DIAM (IN) B	FLOOR TO					WATER CONNECTIONS DISTANCE (IN) G	APPROX SHIP WEIGHT (LBS)
									TOP OF HEATER (IN) C	TOP OF WATER CONNECTIONS (IN) D	SIDE T&P (IN) E	TOP OF VENT (IN) F			
TALL															
GN30T1-3-6	30	29	70	35,000	33	0.60	3	16 ½	59	60 ½	53	62 ¼	8	134	
GN40T1-3-6*	40	38	68	40,000	38	0.59	3	18 ½	59 ¼	60 ¾	54	62 ½	8	145	
GN50T1-3-6*	50	47	85	40,000	38	0.63	3	20 ½	57 ¾	59 ¼	51 ¼	61	8	161	
GN30T2-3-6	30	29	67	35,000	33	0.60	3	18 ½	59	60 ½	53	62 ¼	8	137	
GN40T2-3-6*	40	38	73	40,000	38	0.60	3	20 ½	59 ¼	60 ¾	53	62 ½	8	154	
GN50T2-3-6*	50	47	86	40,000	38	0.66	3	22 ½	57 ¾	59 ¼	51 ¼	61	8	167	
LOW BOY															
GN30L2-3-6	30	29	66	35,000	33	0.60	3	20 ½	47 ¼	48 ¾	41	50 ¾	8	137	
GN40L2-3-6	40	38	62	37,000	35	0.60	3	22 ½	49	50 ½	42 ½	52 ½	8	153	
GN50L2-3-6	50	48	78	40,000	38	0.65	3	24 ½	49 ¾	51 ¼	42 ¾	53	8	183	

Recovery capacity based on actual performance tests

*Model certified to 10,100 feet

- For 12-year models, change the model number suffix from "6" to "12". Example: GN-40L2-3-12.
- All models meet SCAQMD 2008 Rule 1121 and Northern California BAAQMD 2009 10ng/j NOx emissions requirements.
- All models comply with NAECA requirements.
- All models are certified at 300 PSI test pressure and 150 PSI working pressure.
- Dimensions and specifications subject to change without notice in accordance with our policy of continuous product improvement.

SAMPLE SPECIFICATION

Water heater shall be AMERICAN STANDARD WATER HEATERS model _____ having a storage capacity of _____ gallons, operate on Natural Gas with a BTU input of _____ and a recovery rate of _____ gallons per hour at 90°F temperature rise. Water heater tank interior shall be glass lined with Dura-Glas™, furnished with anode rod and insulation shall be non-CFC foam. Water heater shall be CSA certified.

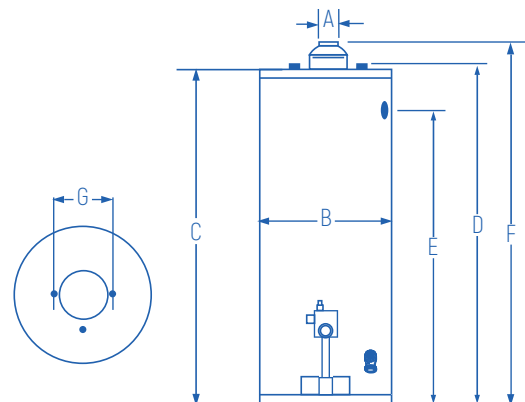

Globally Recognized. Industry Respected.